



## INDEX FOR DETAILED DRAWINGS

Empty ST's in drywalls, masonry or concrete walls.....	page 2
ST's with cables in drywalls, masonry or concrete walls.....	pages 2-4
ST's with pipes etc. in drywalls, masonry or concrete walls.....	page 4
Empty ST's in masonry or concrete walls.....	page 5
ST's with cables in masonry or concrete walls.....	pages 5-6
ST's with pipes etc. in masonry or concrete walls.....	pages 6-7
Empty ST's in floors.....	page 7
ST's with cables in floors.....	pages 7-9
ST's with pipes and conduits in floors.....	page 10

## GENERAL PRODUCT DESCRIPTION

The Protecta® Service Transit has been designed to maintain the fire resistance of walls and floors when these are breached by continuous cables and plastic pipes. The Service Transit consists of a circular high temperature plastic tube containing a graphite based intumescent lining material which expands upon heating to seal spaces or voids around cables and pipes, thus preventing the passage of flames, smoke and gases. After installation of the Service Transit, cables and pipes can be retrofitted without having to install a new fire seal. The Service Transit is available in three different lengths, 150mm, 250mm and 400mm and the selection of which to use depends on the thickness of the supporting construction and the required fire classification.

## GENERAL GUIDE

**Minimum separations and limitations:** Service Transits can be fitted as specified in the detailed drawings from page 2.

**Friction fitted:** Minimum separation between Service Transits should be at least 30 mm.

**Fitted with Protecta® FR Acrylic:** Minimum separation between a Service Transit and the edge of the seal should be 10 mm and minimum separation between apertures should be 30 mm.

**Fitted within Protecta® FR Board or EX Mortar:** An aperture can include several services, and they may also be different. Minimum separation between Service Transits and also between Service Transits and the edge of the aperture should be 30 mm. The minimum permitted separation between adjacent apertures is 200 mm.

**Supporting constructions:** Flexible walls must have a minimum thickness of 75 mm and comprise steel studs or timber studs\*) lined on both faces with minimum 1 layer of 12.5 mm thick boards. Rigid walls must have a minimum thickness of 75 mm and comprise concrete, aerated concrete or masonry, with a minimum density of 650 kg/m<sup>3</sup>. Rigid floors must have a minimum thickness of 150 mm and comprise aerated concrete or concrete with a minimum density of 650 kg/m<sup>3</sup>. The supporting construction must be classified in accordance with EN 13501-2 for the required fire resistance period.

\*) Timber studs: no part of the penetration seal may be closer than 100 mm to a stud, and minimum 100 mm of insulation of class A1 or A2 according to EN 13501-1 must be provided within the cavity between the penetration seal and the stud.

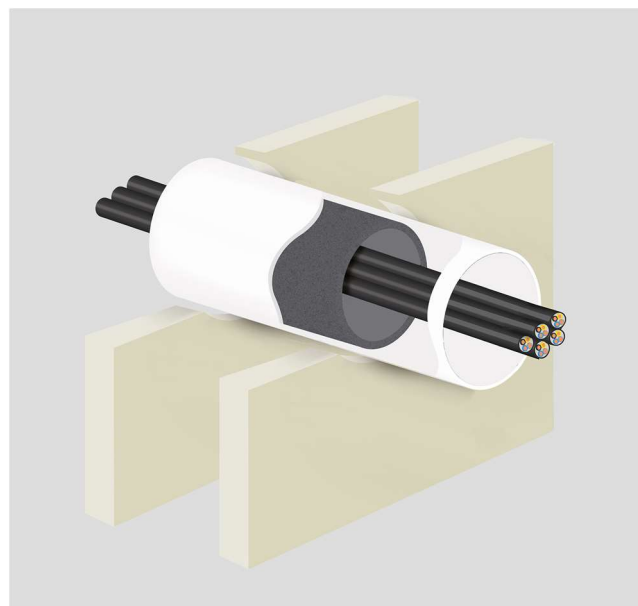

## INSTALLATION

1. Install the Service Transit centrally in the wall, floor or fire seal ensuring that the center point of the transit is located mid-depth in the wall, floor or fire seal.
2. **Friction fitted or cast installation:**  
Make sure there is a tight seal with no gaps around the Service Transit and that it is securely locked in position. If this is not the case, simply apply a bead of Protecta® FR Acrylic on both sides.  
**Installation with Protecta® FR Acrylic, FR Board or EX Mortar:**  
Follow the Technical Data Sheet and Installation Instructions supplied with the product selected together with installation instructions and detailed drawings in this document.
3. Before cables and/or plastic pipes are inserted through the Service Transit, remove the fiber plug from the middle of the Service Transit. After the insertion of services is completed, ensure that the fiber plug is refitted and positioned correctly around the services in the middle of the Service Transit, leaving no openings so a cold smoke barrier is achieved.
4. Make sure labels with retrofit instructions are placed near the Service Transit on both sides after installation, so future service installations are completed correctly by reinstating the fiber plug.

## TEST STANDARDS

This Installation Instruction is based on the product's European Technical Assessment, issued in accordance with regulation (EU) No 305/2011, on the basis of EAD 350454-00-1104, September 2017.

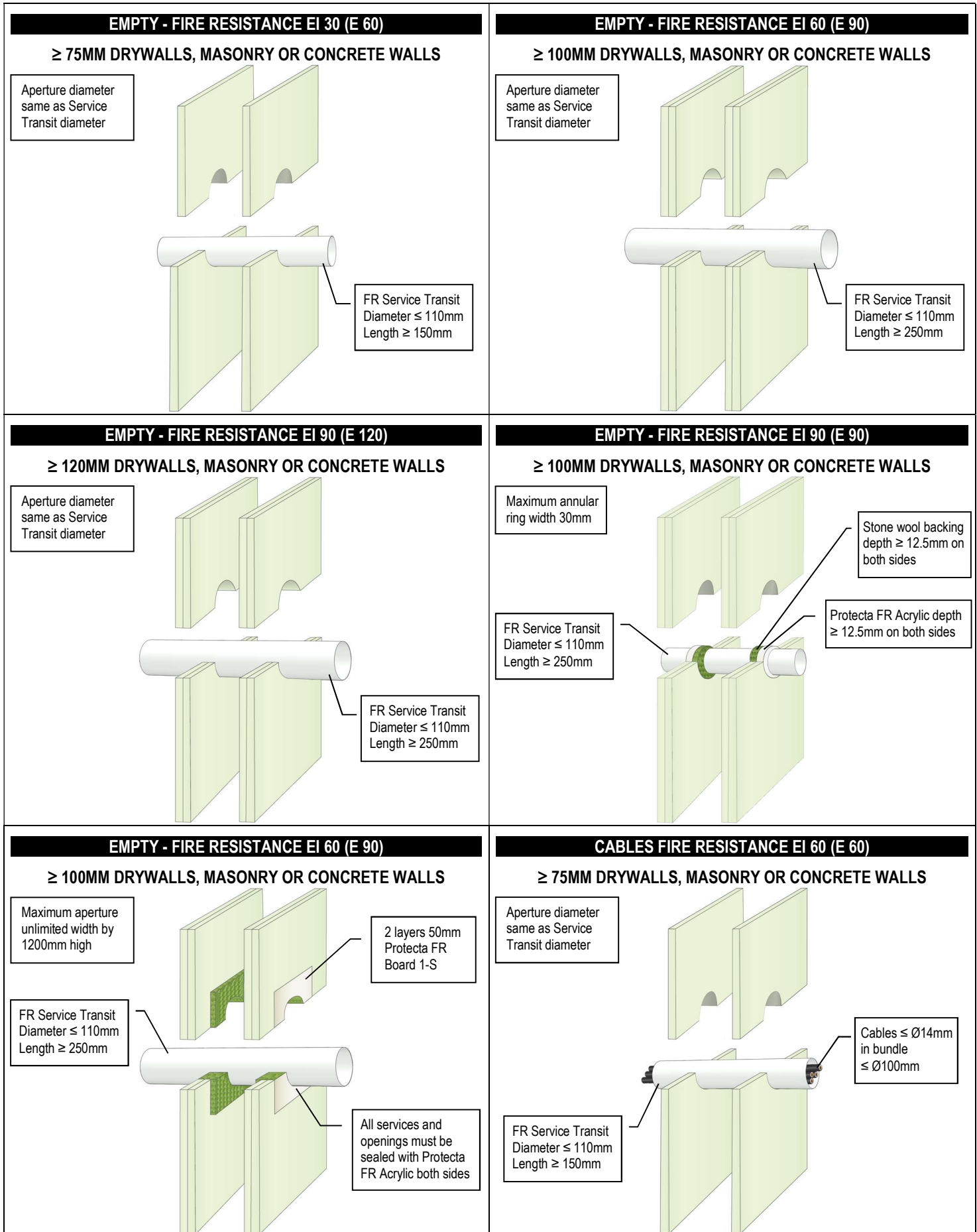

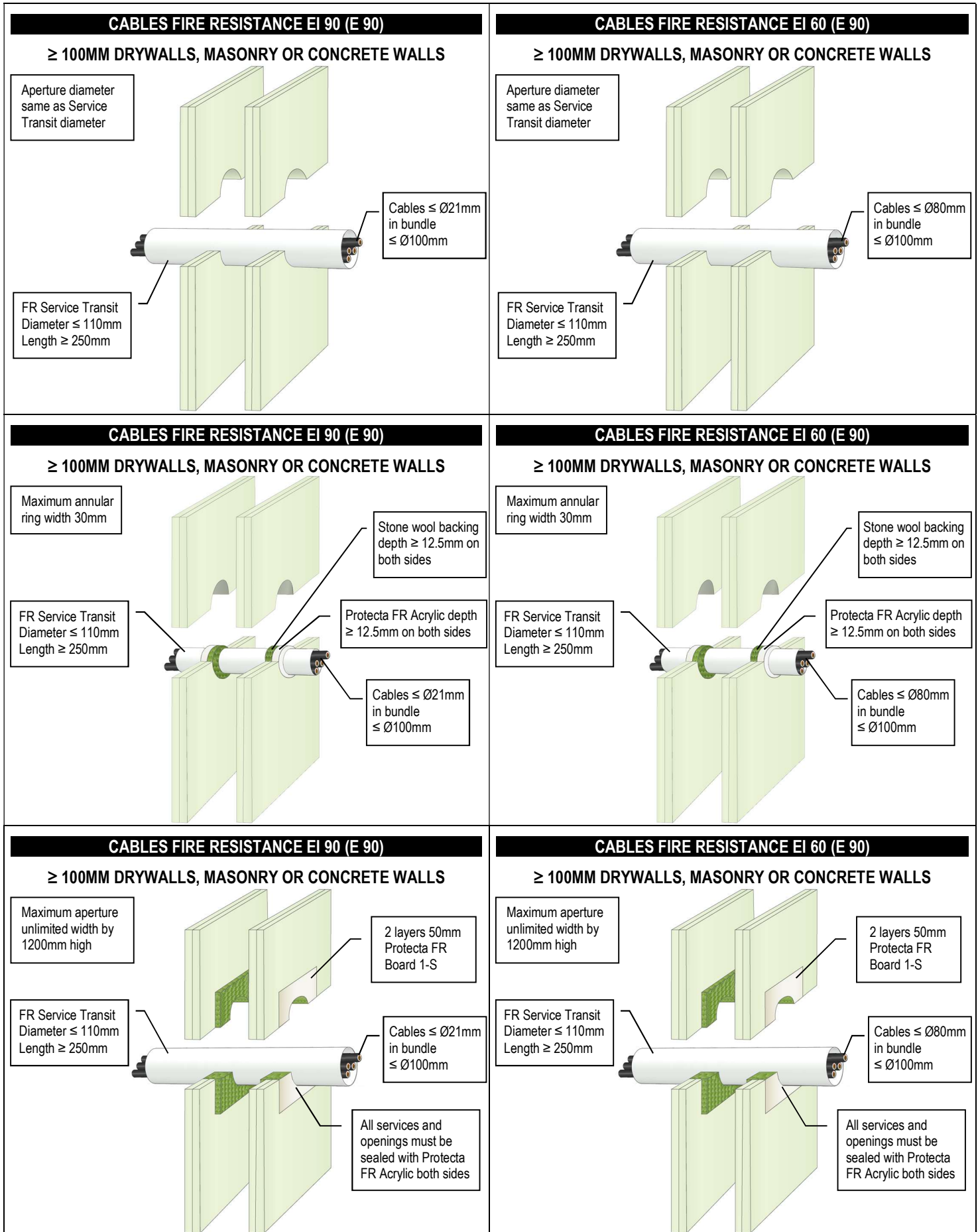

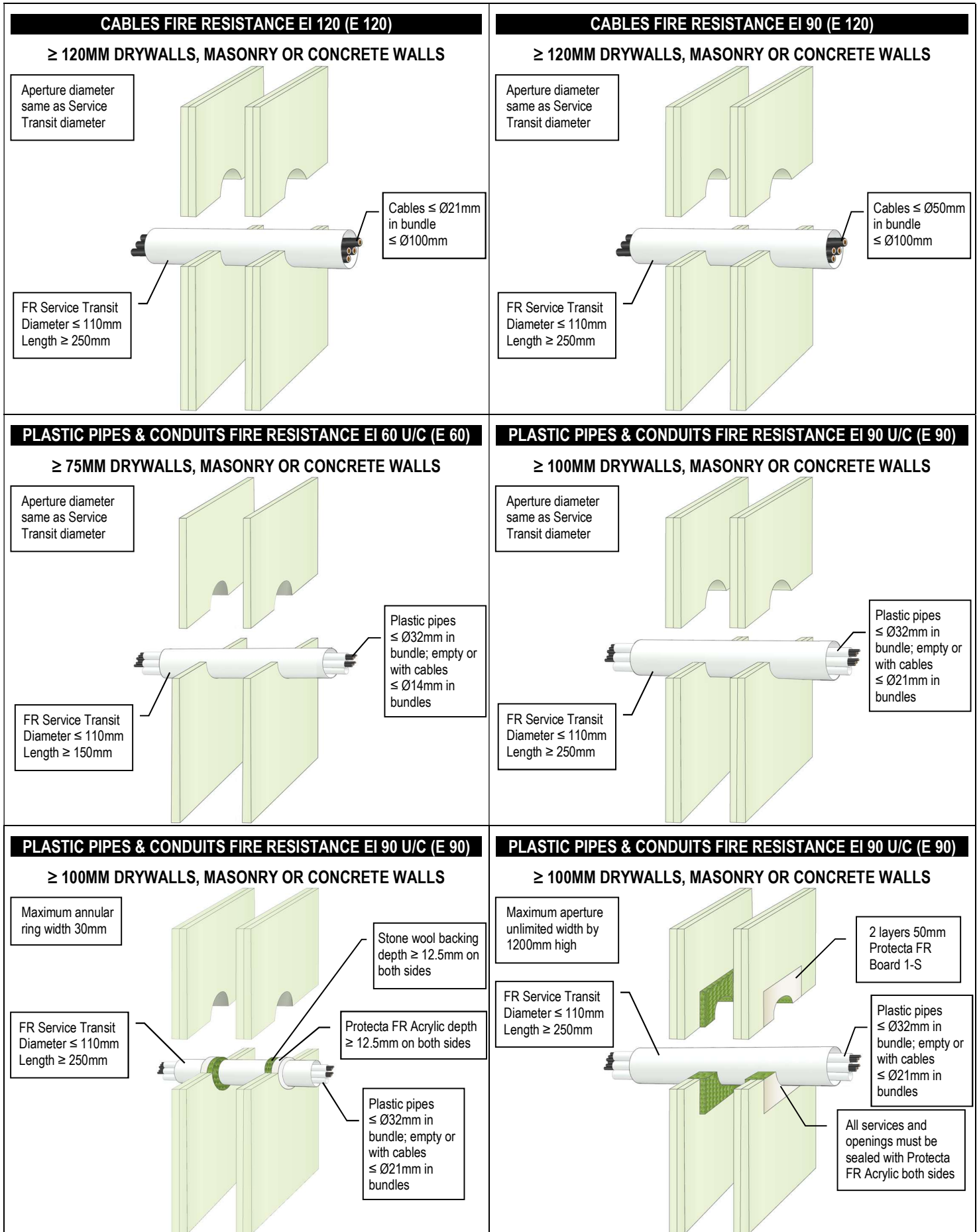



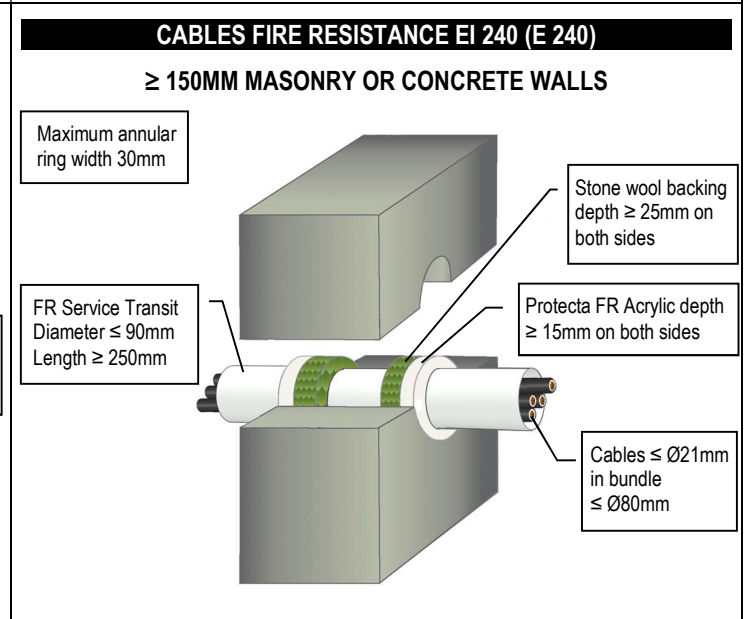
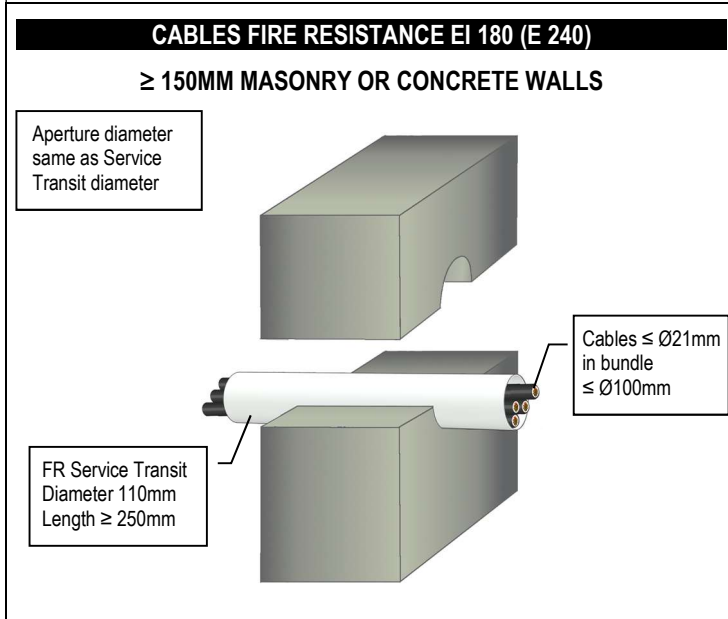
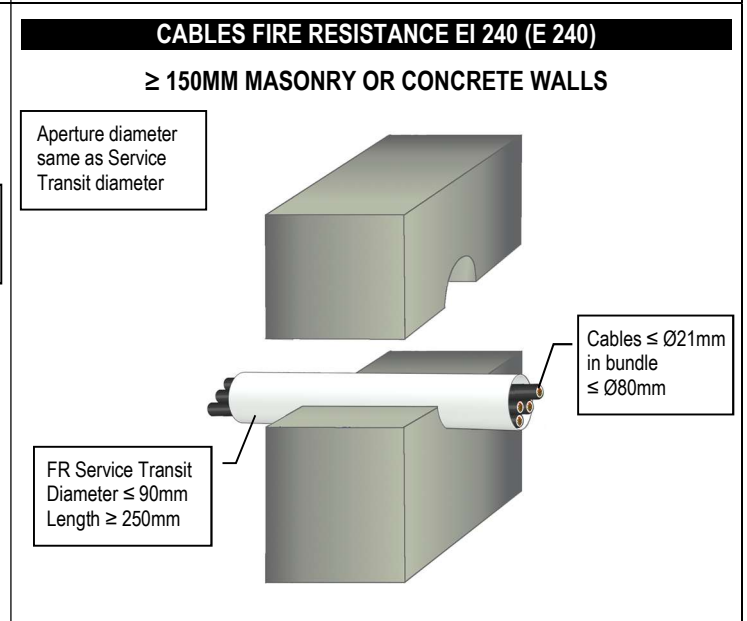
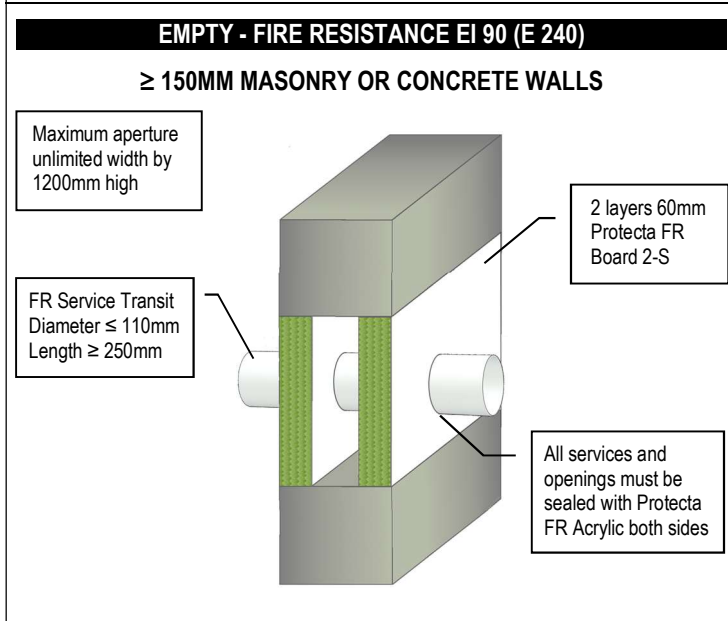
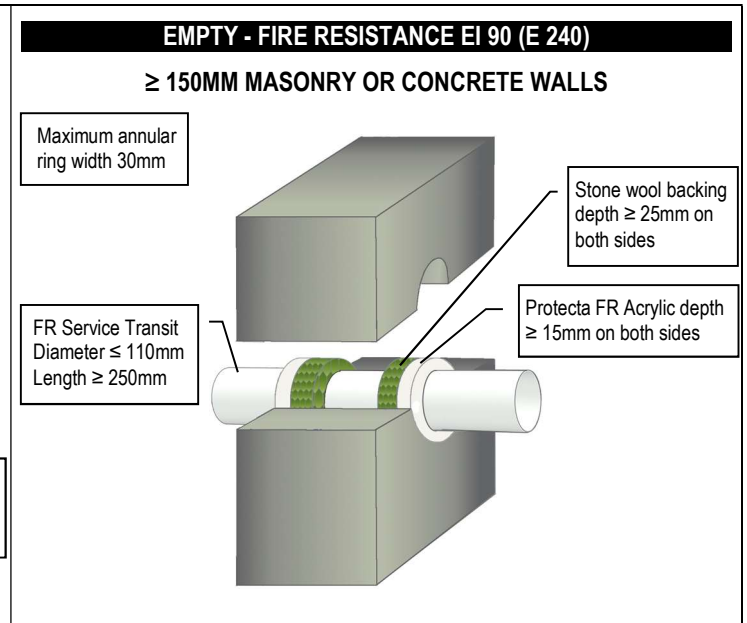
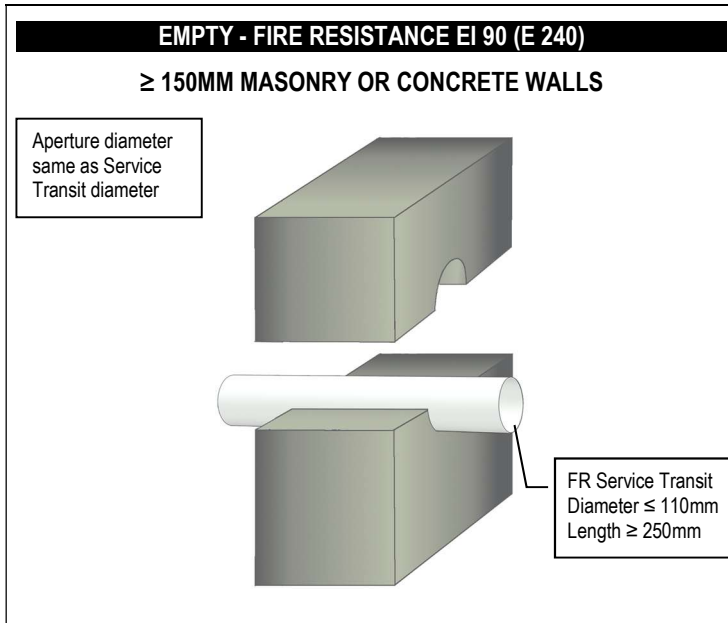

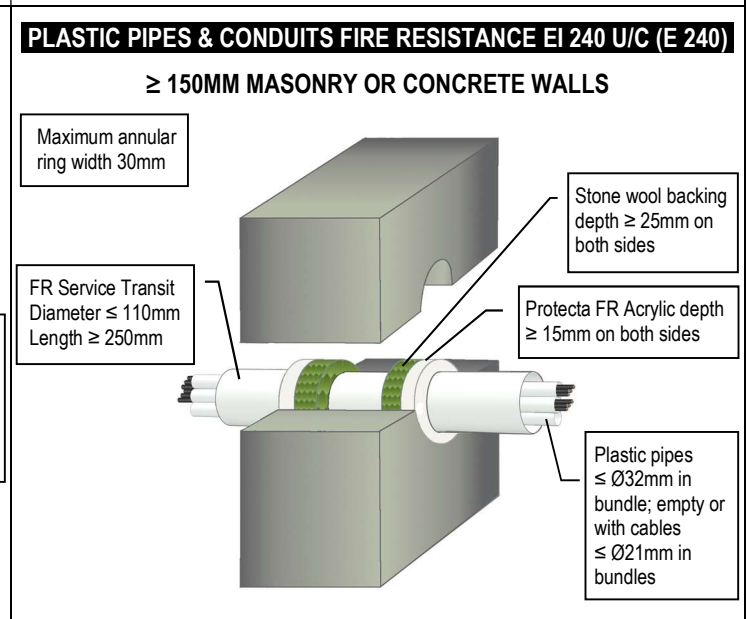
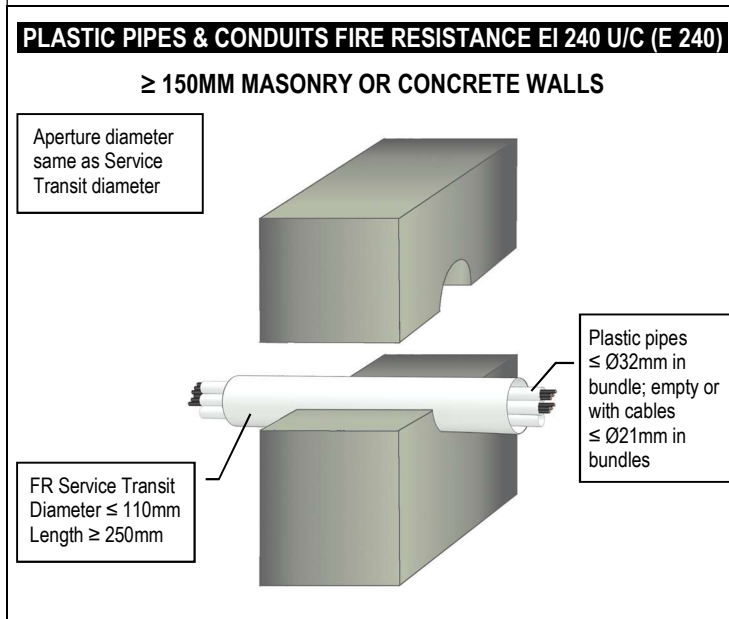
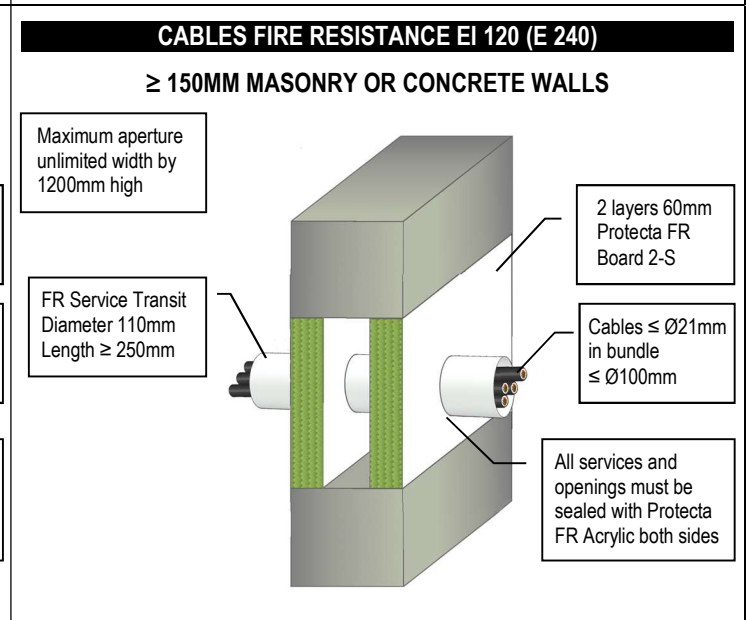
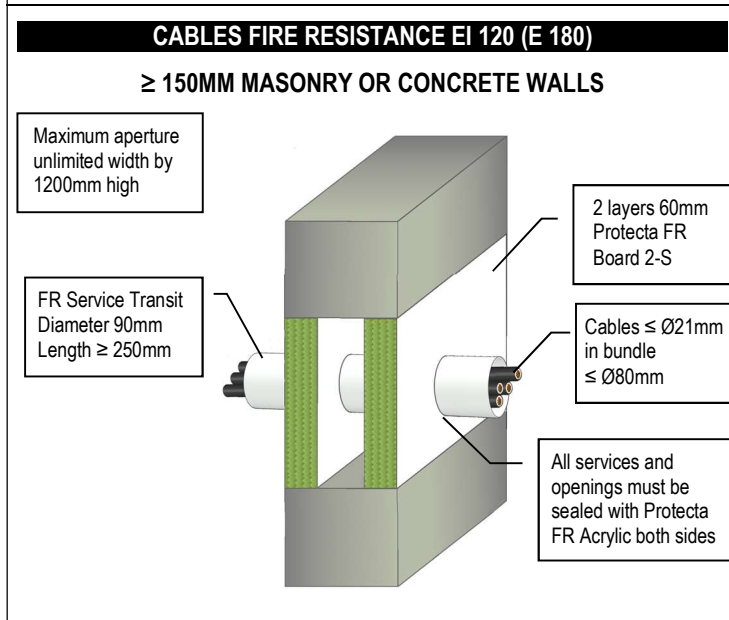
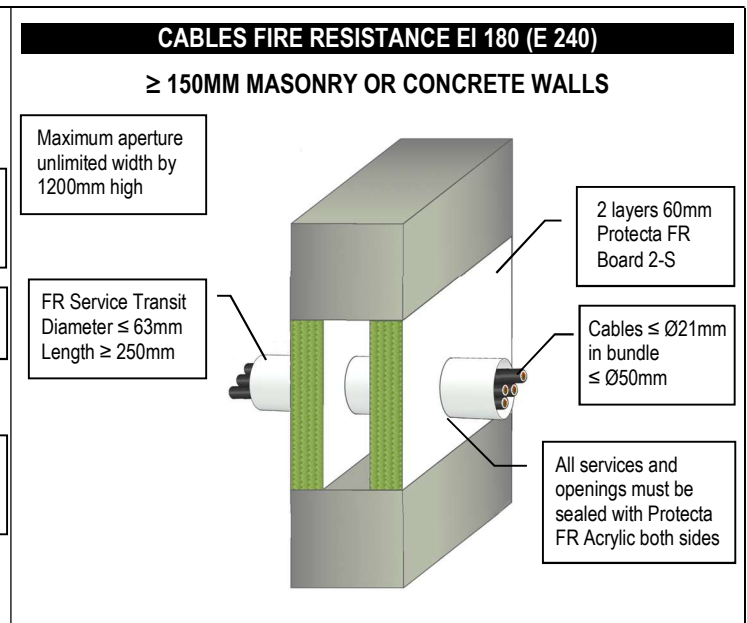
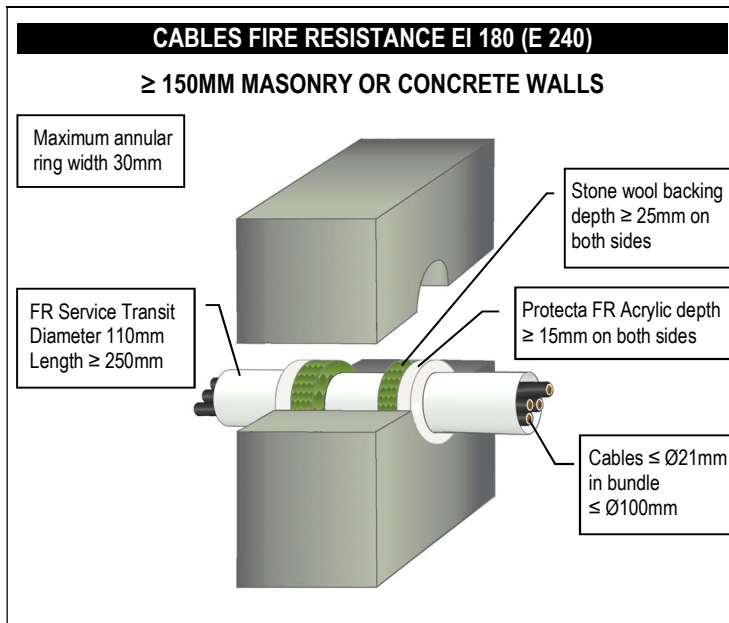

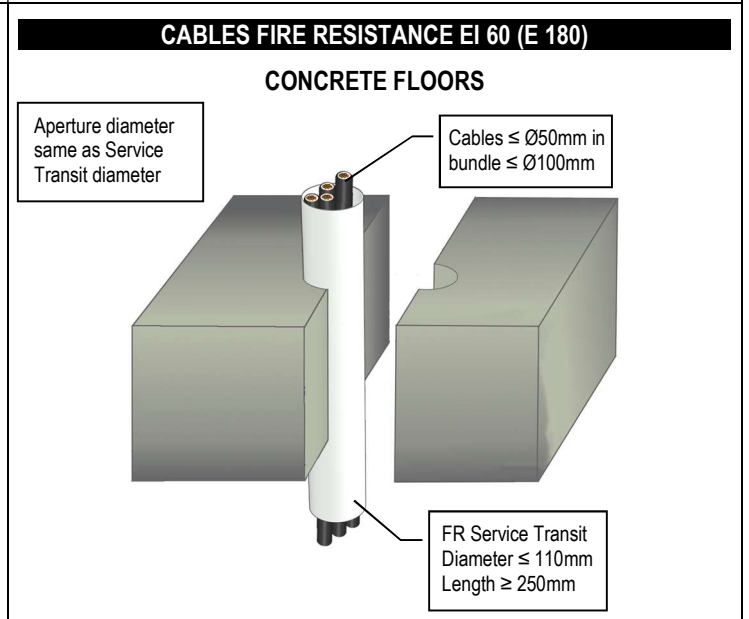
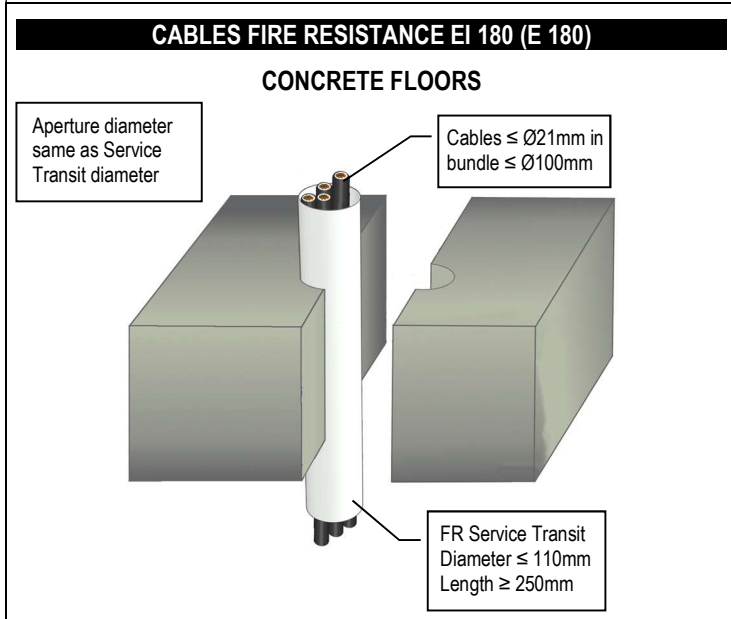
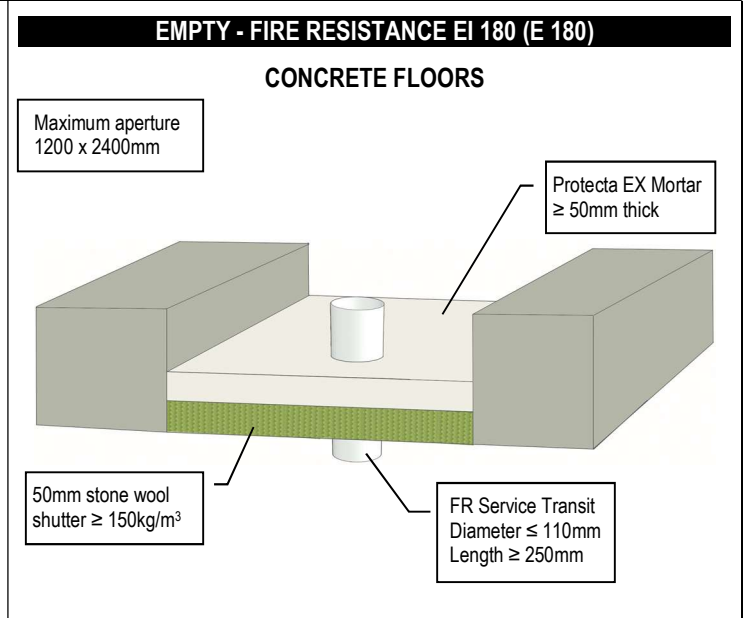
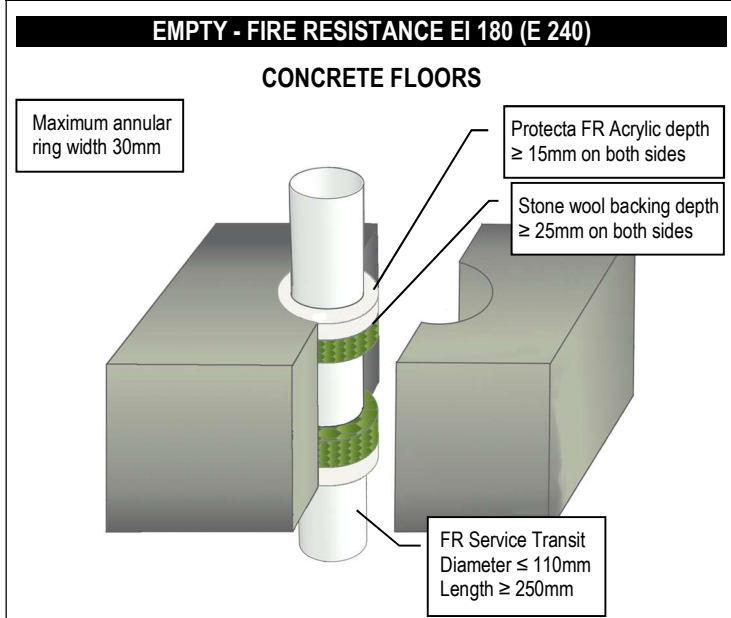
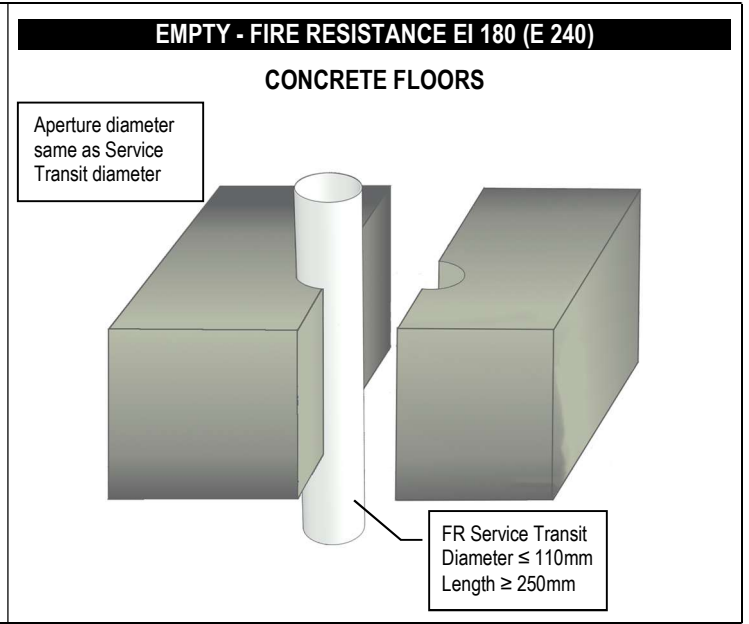
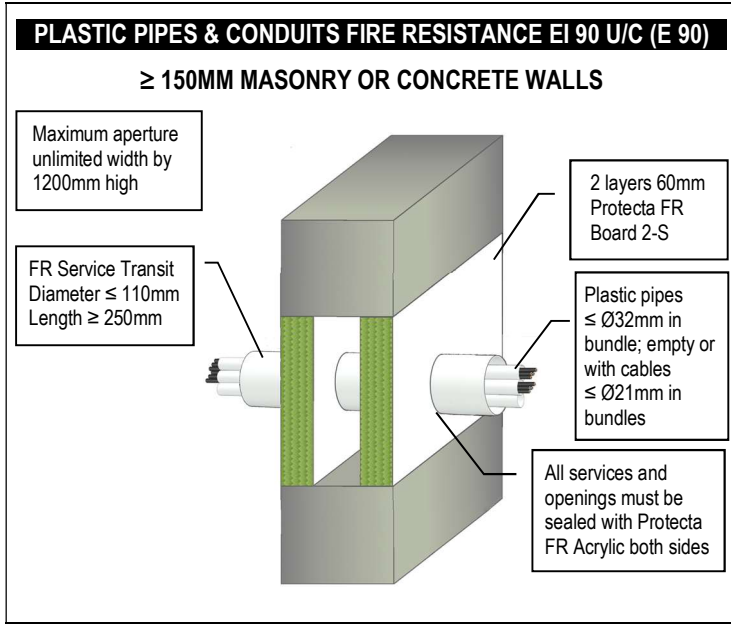

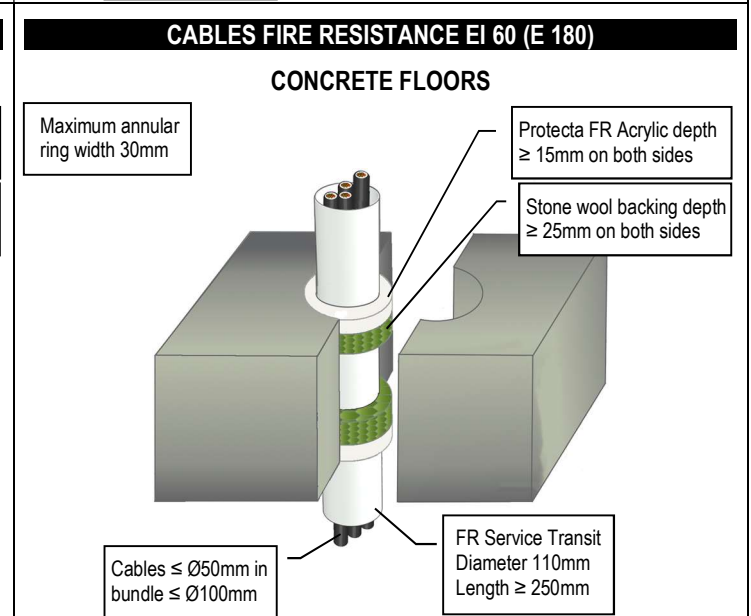
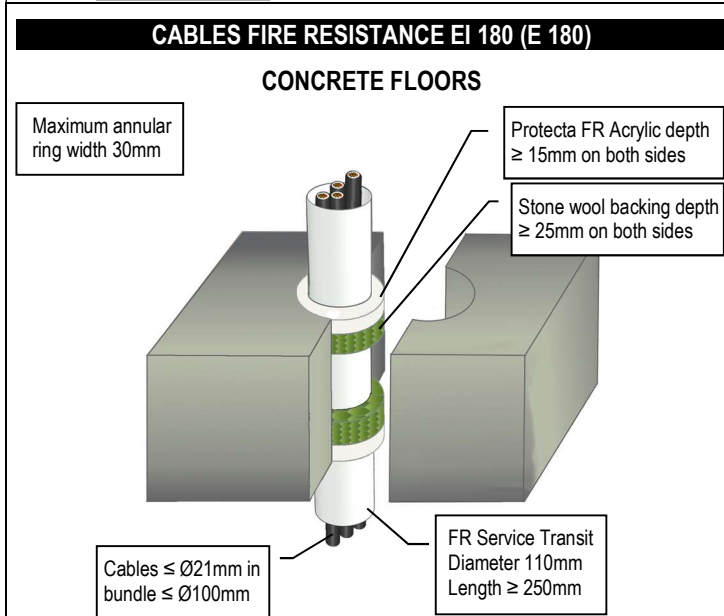
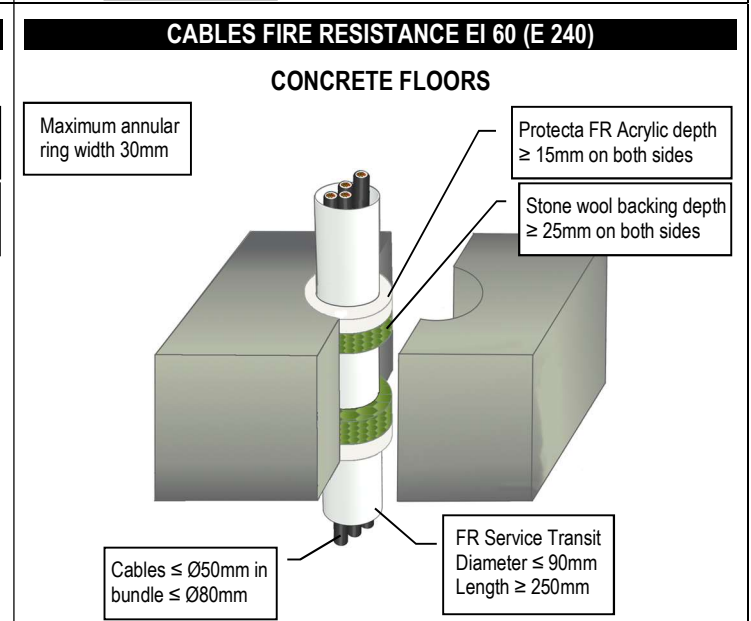
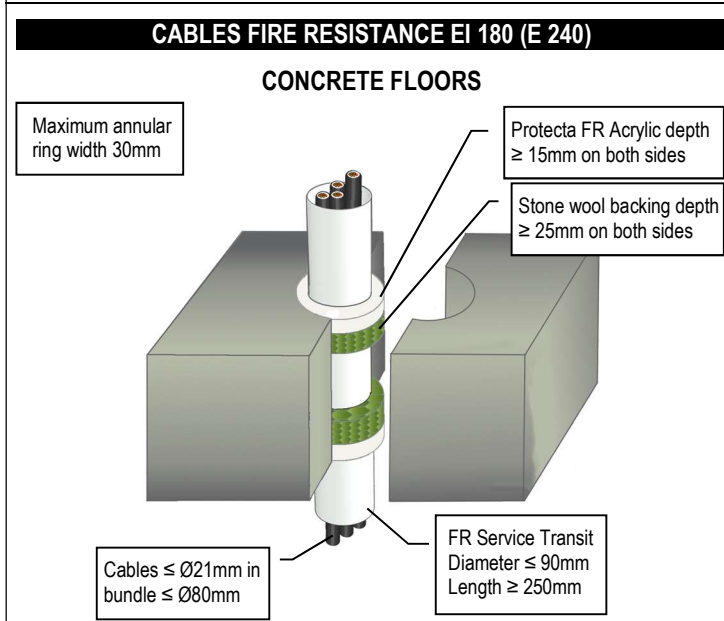
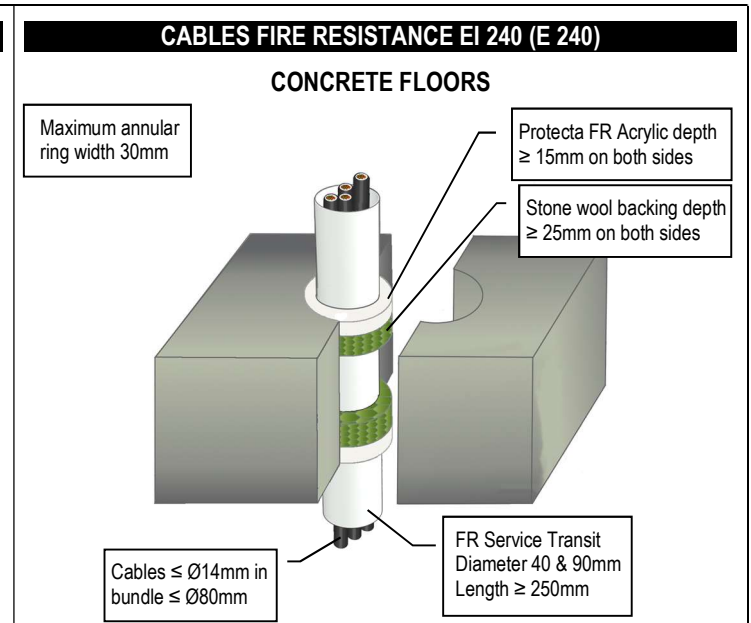
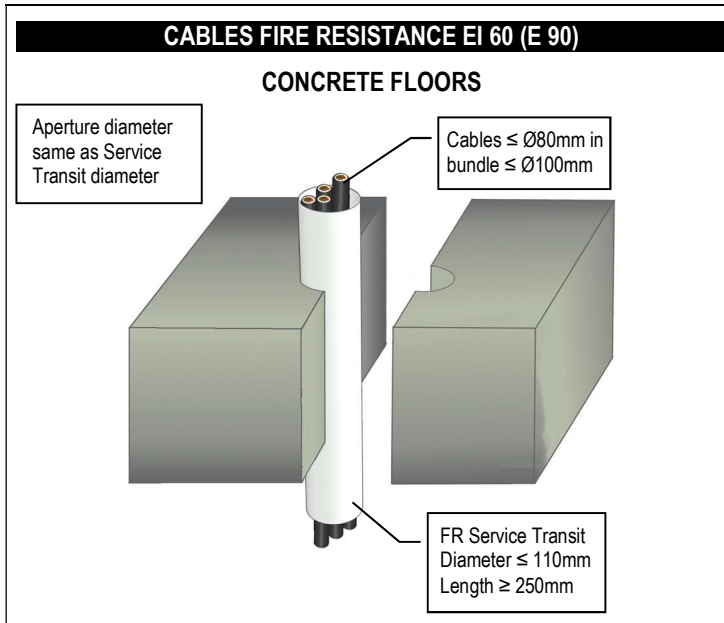



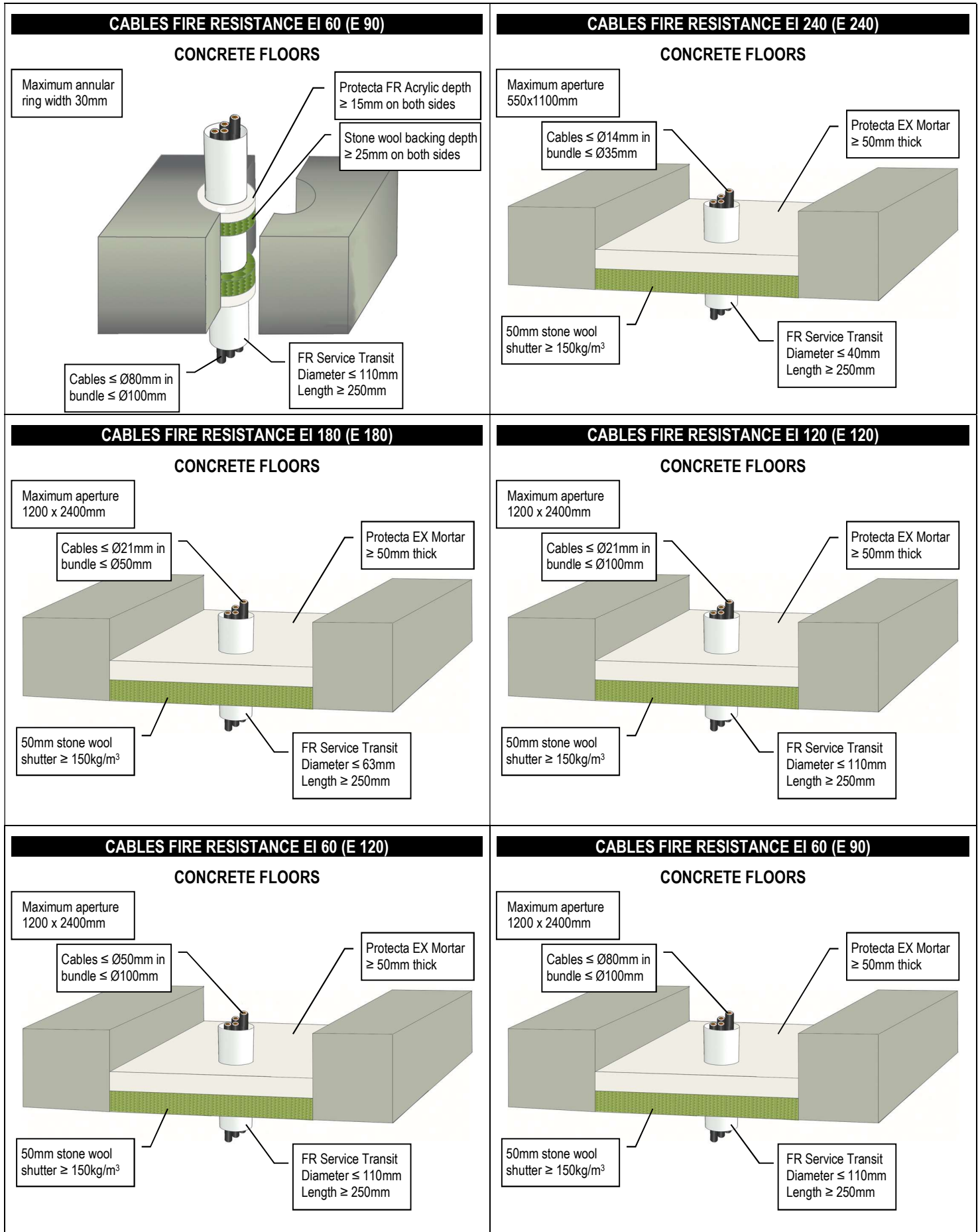

**PLASTIC PIPES & CONDUITS FIRE RESISTANCE EI 180 C/U (E 180)**

**CONCRETE FLOORS**

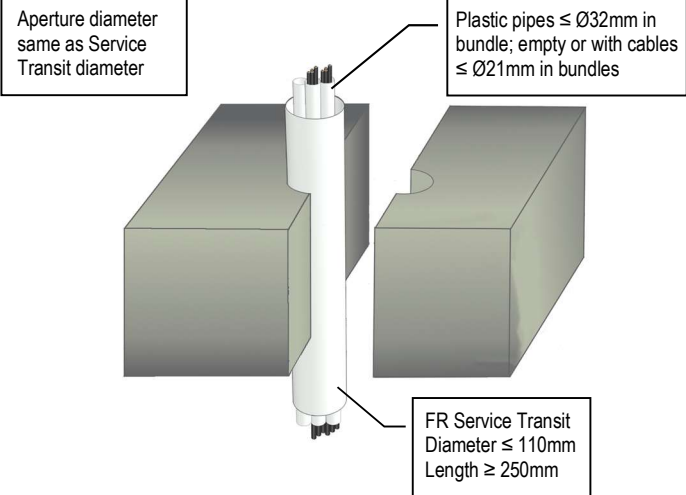

**PLASTIC PIPES & CONDUITS FIRE RESISTANCE EI 180 C/U (E 180)**

**CONCRETE FLOORS**

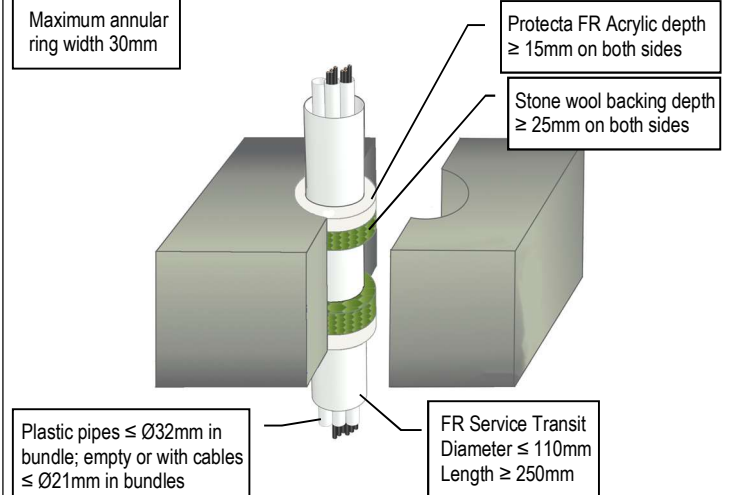

**PLASTIC PIPES & CONDUITS FIRE RESISTANCE EI 120 C/U (E 120)**

**CONCRETE FLOORS**

