

Talentum[®] I6531

Stainless Steel UV/IR² Flame Detector

The Talentum[®] Ultra-Violet, dual Infra-Red (UV/IR²) Flame Detector is designed to protect areas where open fires may be expected. Talentum detects all flames, from hydrocarbon fires with 4.3µm emissions through to invisible fires such as hydrogen.

The UV/IR² Flame Detector is sensitive to flickering, low frequency (1-15Hz) infra-red radiation along with ultra-violet emitted by flames during combustion.

This detector has a UV sensor and two IR sensors which respond to different wavelengths of both the ultra-violet and the infra-red spectrum. The signals from these sensors are processed by the detector and checked for characteristics of a flame. The simultaneous detection of both the UV and the IR light by the sensors will signal an alarm. False alarms from flickering sunlight, arc welding and lightning are eliminated by a combination of UV and dual IR signal processing techniques.

The Talentum[®] UV/IR² detector has selectable output options of relay contacts or 4 to 20mA signal as standard.

Features

- Highest immunity to false sources
- Solar blind
- Suitable for indoor and outdoor areas
- Unaffected by convection currents, draughts or wind
- Proven response to multiple fuel types
- Multi-spectrum detection
- Selectable output options
- Selectable response speed
- Selectable sensitivity levels
- Built in auto and manual test
- Low current consumption
- Fast response to fire

Approvals

Worldwide approvals include EN54:10, with VdS and LPCB certification, as well as SIL 2 rated.

Visit www.ffeu.com for up to date approvals information.



Applications

- Applications
- Refineries
- Generators
- Compressor Stations
- High Voltage Equipment
- Power Plants
- Fuel Loading Racks
- Chemical Plants
- Tunnels
- Nuclear Power Sites
- Storage Tanks
- Engine Rooms
- Pharmaceutical Production
- Military Applications
- Marine Industry
- Aircraft Hangars
- Petrochemical Offshore/Onshore
- LNG/LPG Production

Accessories

07127 Stainless Steel Adjustable Mount (316)

12545 Stainless Steel Weather Shield (304)

16091 Portable Flame Detector Tester



Mechanical Specification

Housing Material	Stainless Steel 316
Housing Colour	Natural
Dimensions	142(H) x 108(W) x 82(D) mm
Weight	2.kg
Cable Gland Entries	2 x 20mm
Wiring	1.0 to 4.0mm ²

Electrical Specification

Supply Voltage	14 to 30Vdc
Quiescent Current	8mA, RL2 energised 4mA, current loop, RL2 off 3mA, RL2 off
Alarm Current	28mA, RL1 & RL2 energised 20mA, current loop, RL1 & 2 off 9mA, RL1 energised
Power Up Time	2 seconds max.
Test Signal Voltage	14 to 30Vdc
Relay Outputs	
- Programmable	Normally Open or Normally Closed Latching or Non-latching
- Ratings: Current Voltage Power	1.0A Max. 50Vdc Max. 30W Max. (Note: Resistive Loads Only)

Environmental

Operating Temperature	-10°C to +55°C
Storage Temperature	-20°C to +65°C
Relative Humidity	95% Non condensing
IP Rating I	IP65

Performance

Range - Class 1* - Class 3	0.1m ² n-heptane at 25m 0.1m ² n-heptane at 12m (see EN54:10 for sensitivity settings)
Field of View	90° min. Cone
Spectral Response	
- UV	185 to 260nm
- IR	1.0 to 2.7µm

Approvals

CPR	0832-CPR-0584
LPCB	729a/12
VdS	G212190
SIL 2	C127_CT001_(2.0)

Response Characteristics – High Sensitivity

Fuel	Flame Size m (ft)	Distance m (ft)	Factory Tested Distance m (ft)	Average Response time (seconds)
n-Heptane* (Yellow flame)	0.3 x 0.3 (1 x 1)	25 (82)	60 (196)	8
Methylated Spirit* (Clear flame)	0.5 x 0.5 (1.6 x 1.6)	25 (82)	60 (196)	12
Hydrogen (non-visible flame)	0.1 x 0.5 (0.3 x 1.6)	12 (39)	30 (98)	16

* has been tested and approved at Class I

Field of View

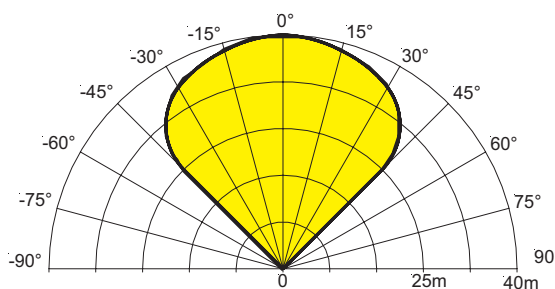

To meet the requirements of EN54:10 clause 5.4, where the ratio of the response points $D_{max} : D_{min}$ should not exceed 1.41, the horizontal and vertical viewing angles max should not exceed $\pm 30^\circ$.

Flame Detector

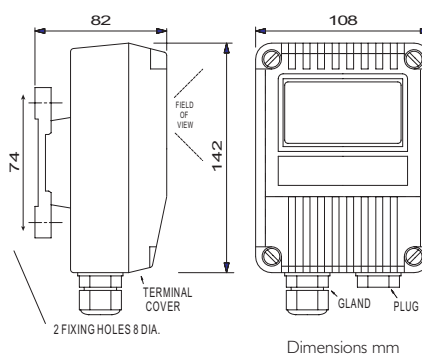

Mounting Bracket

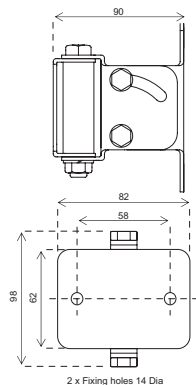

Installation Recommendations

Please refer to our User Manual for mounting and wiring instructions. The installation of Talentum® flame detectors should be undertaken in accordance with the recognised national or international standards and codes of practice.

Specifications and wiring information are provided for information only and are believed to be accurate. FFE Ltd assumes no responsibility for their use. Data and design are subject to change without notice. Installation and wiring instructions are shipped with the products and should always be used for actual installation. For more information, contact your Sales Representative.

Document Part No: 24-0261-01



FFE Limited
9 Hunting Gate Hitchin,
Hertfordshire SG4 0TJ UK

t +44 (0) 1462 444 740
e sales@ffeuk.com
w www.ffeuk.com