



PS-15012100
PS 12V/10A enclosed switch mode power supply



Edition: 10 from 01.03.2018
Supersedes the edition: 9 from 27.05.2014

EN

Features:

- power output 10A/12÷15V DC*
- wide range of AC input voltage 176÷264V
- high efficiency 83%
- LED indication
- protections:
 - short-circuit protection SCP
 - over voltage protection OVP
 - surge protection
 - overload protection OLP
- warranty – 2 year from the production date

1. Technical description.

1.1. General description.

The power supply unit is intended for 230V AC mains supply to alarm system devices, which require 12V DC voltage and current efficiency of **I=10A**. The design enables simple changing of the output voltage, within the range of 12V÷15V DC, using a potentiometer. The power supply unit is protected against a short circuit, an overload, a surge or over voltage.

1.2. Specifications.

Supply voltage	176 ÷ 264V AC; 50÷60Hz
Current consumption	1,1A@230V AC max.
PSU power	150W max.
Efficiency	83%
Output current t_{AMB}<30°C	10A - see chart 1.
Output current t_{AMB}=40°C	7A - see chart 1.
Voltage adjustment range	12V ÷ 15V DC
Ripple voltage	100mV p-p max.
Short-circuit protection SCP	electronic (activation requires disconnecting the load or supply for about 5 s.)
Overload protection OLP	105 ÷ 150% of the PSU power (activation requires disconnecting the load or supply for about 5 s.)
Surge protection	varistors
Over voltage protection OVP	>16V (activation requires disconnecting the load or supply for about 20 s.)
LED indication	green LED – presence of DC voltage
Operation conditions	2-nd environmental class, temperature: -10°C ÷ +40°C relative humidity 20%...90%, without condensation
Dimensions	L=199, W=110, H=50 [+/- 2mm]
Net/gross weight	0,73kg / 0,78kg
Protection class PN-EN 60950-1:2007	I (first) – requires a protective conductor (PE)
Connectors	power-supply: Φ0,63-2,50 (AWG 22-10) outputs: Φ0,63-2,50 (AWG 22-10)
Dielectric strength of insulation: - between input (network) circuit and output circuits of the PSU (I/PO/P) - between input circuit and PE protection circuit (I/P-FG) - between output circuit and PE protection circuit (O/P-FG)	3000 V/AC min. 1500 V/AC min. 500 V/AC min.
Insulation resistance: - between input circuit and output or protection circuit	100 MΩ, 500V DC
Storage temperature	-20°C...+60°C
Vibrations and impulse waves during transport	PN-83/T-42106

* In order to extend the life of the power supply, the load current of 7A is recommended.

* See graph 1.

1.3. Temperature characteristics.

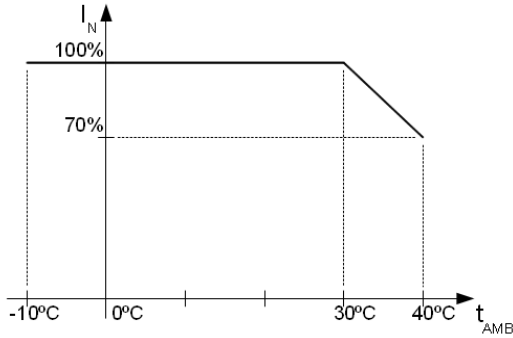

Chart 1.
Acceptable output current from the PSU depending on ambient temperature (instantaneous load).

2. Installation.

2.1. Requirements.

The PSU is to be mounted by a qualified installer, holding relevant permits and licenses (applicable and required for a given country) for 230V AC and low-voltage installations. The unit should be mounted in confined spaces, according to the environment class II, of normal air humidity (RH=90% max. without condensation) and the temperature from -10°C to +40°C.

The device shall be mounted in a metallic enclosure (a cabinet, a final case). In order to fulfil LVD and EMC requirements the rules for power-supply, encasing and screening shall be followed, according to application.

It is crucial to connect the PE wire to the corresponding connector of the supply unit.

2.2. Installation procedure.

1. Before installation of the power supply unit, make sure that 230V AC power is cut off.
2. Mount the unit in the previously selected location.
3. Connect the 230V AC power cables. Connect the PE cable (yellow-green) to an appropriate PSU terminal (marked with \perp - earth symbol).



The shock protection circuit shall be performed with a particular care: the yellow and green wire coat of the power cable shall stick to one side of the appropriate PSU terminal.

Operation of the PSU without a properly made and fully operational shock protection circuit is UNACCEPTABLE! It can cause a device failure or an electric shock.

4. Connect load/loads to proper output connectors of the power supply (positive pole is marked as +V, negative pole as COM).
5. Once the tests and operation control have been completed, lock the enclosure/cabinet, etc.

2.3. Description of the connectors

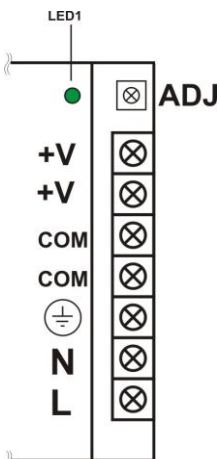

Fig.1. Description of the connectors.

Elements/connectors [Fig.1]	Description
L, N, \perp	L-N - 230V AC voltage connector, \perp - connector for protective conductor
COM	Ground
+V	PSU output (+12V)
LED1	LED indicating voltage at the PSU output
ADJ	Potentiometer - output voltage adjustment

2.4. Dimensions and fitting of the PS-15012100 power supply.

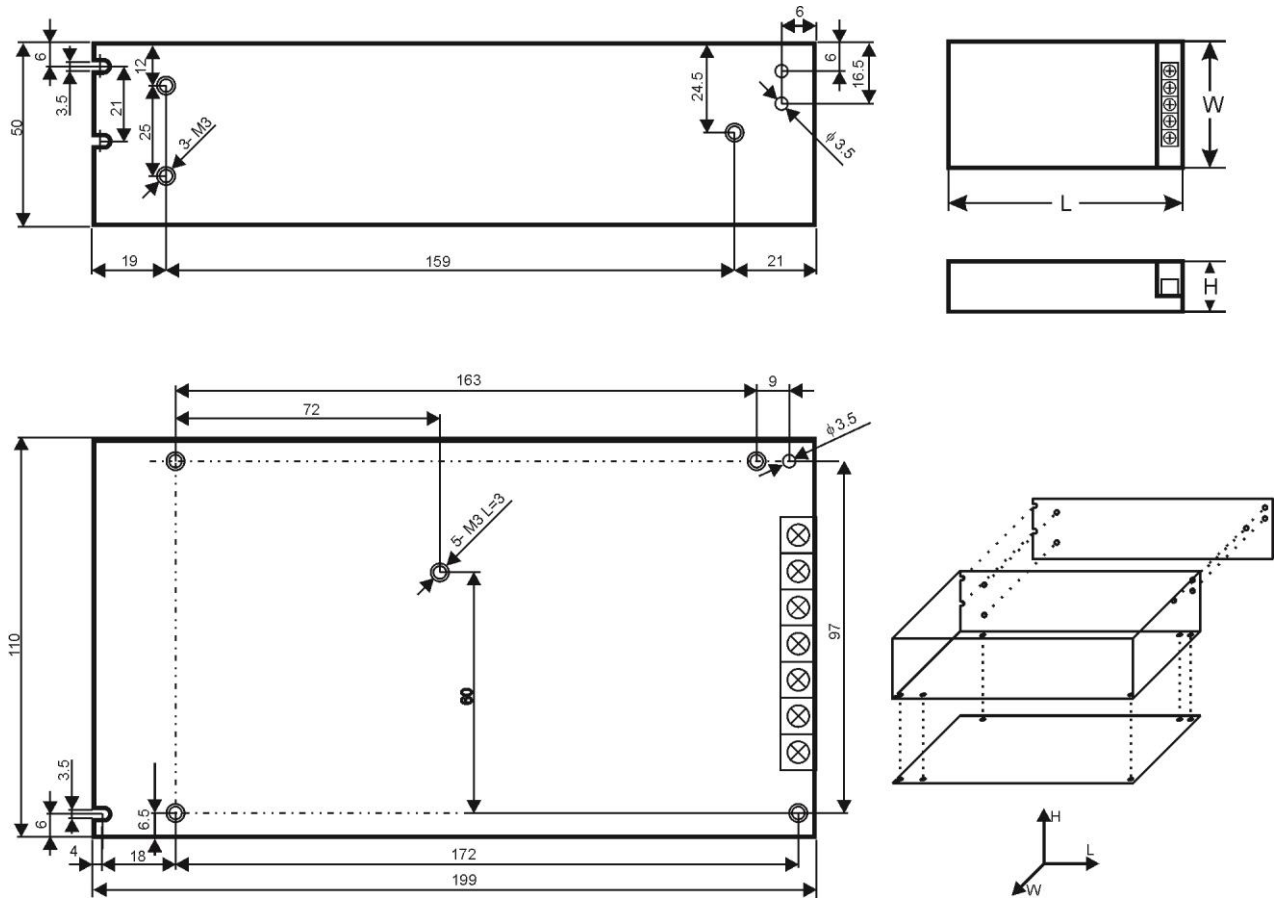

Fig. 2. Mechanical view of the PSU.

3. Maintenance.

Any and all maintenance operations may be performed following the disconnection of the PSU from the power supply network. The PSU does not require performing any specific maintenance measures, however, in the case of a significant dust level, it is recommended to clean its interior with compressed air

WEEE MARKING



According to the EU WEE Directive – It is required not to dispose of electric or electronic waste as unsorted municipal waste and to collect such WEEE separately.

Pulsar

Siedlec 150, 32-744 Łapczyca, Poland
Tel. (+48) 14-610-19-40, Fax. (+48) 14-610-19-50
e-mail: biuro@pulsar.pl, sales@pulsar.pl
http:// www.pulsar.pl, www.zasilacze.pl